

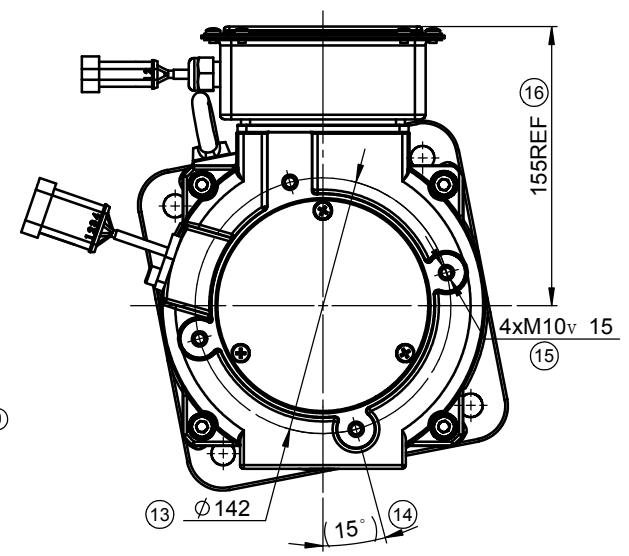

PART NO.	SDK5-1191 ACIM Motor
REV B	V1-161210

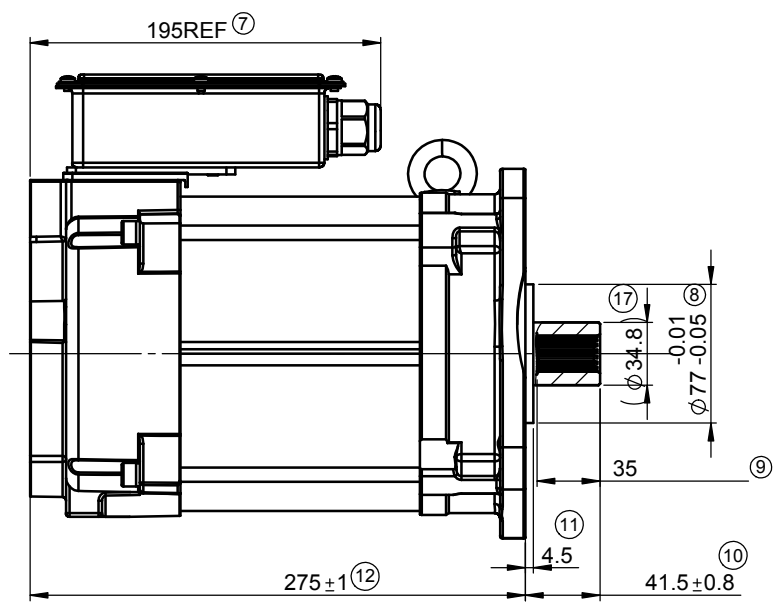
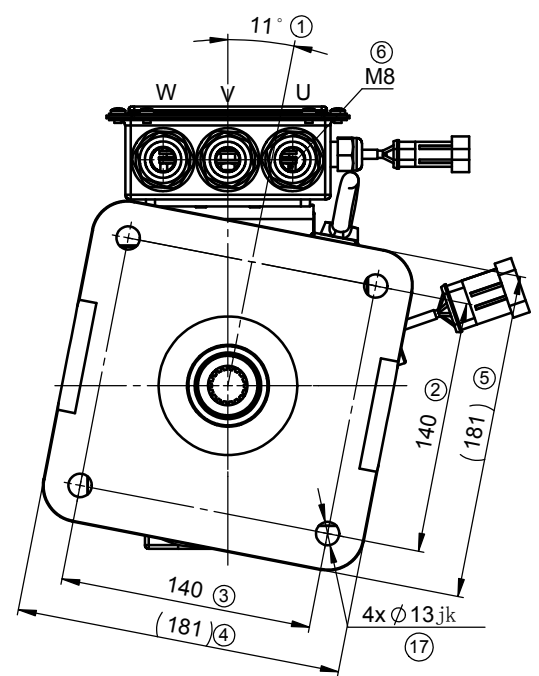

Internal involute spline data 内花键参数表:	
Tooth profile 齿形	Normal shift 低齿 (正变位)
Module 模数 m	1.0
Pressure 压力角 α	20°
Number of tooth 齿数 Za	18
Pitch diameter 分度圆直径	Φ18
Major diameter 大径	Φ19.98
Minor diameter 小径	Φ17.8
Addendum modification 径向变位系数	+0.8
Trans-number of teeth 跨测齿数 R	3
Base tangent length 公法线长度 W	8.18
Dimension between two pins 跨棒距 M	16.067 ^{+0.071} ₀
Pin diameter 量棒直径	Φ2
Form of coordination 配合形式	side centering 齿侧定心

PIN NUMBER	PIN FUNCTION
SPEED SENSOR	
1	+V RED OR YELLOW
2	SIGNAL "A" WHITE
3	SIGNAL "B" BLUE
4	GROUND BLACK
THERMAL SENSOR	
1	+ RED
2	- BLACK

DWG JONES CHO	DATE	PROPRIETARY THIS TECHNICAL DATA IS PROPRIETARY TO STARS CO., LTD.	 STARS CO., LTD. TAIWAN
CHECK SHIN WANG	DATE		
APPROVED JONES CHO	DATE		
		TITLE	SDK5-1191 AC Induction Motor
		DOCUMENT NO.	REV. 161210
		FILE:	SHEET 1 OF 1